

## How To Use Our Riveting System



This new riveting system is designed to pierce and set semi-tubular rivets. Semi-tubular rivets have a solid head that creates a finished look, and a tubular end that is set by a flaring method to create a secure, clean, and consistent connection.

The tool features a piercing tool on one end that creates the hole to accommodate the rivet. The other end is a flaring tool which precisely and cleanly sets the rivet.

This versatile tool base is also engineered to be interchangeable. As new sizes of piercing and flaring sets become available, they can be purchased separately and be quickly installed into the tool base, allowing you flexibility in one compact tool.

Visit our YouTube Channel to see a demo video of the Riveting System's operation:

<http://www.youtube.com/CraftedFindings>

**Step 1** Although this compact tool can be operated with your hands only, we suggest securing the tool in a vise as shown in Photo 1 on right.

This allows an easier and more secure operation when holding your work piece and operating the tool handles. And, by orienting the tool in a horizontal position, as shown, it makes aligning the rivets easier. The rivets stay in position horizontally with less chance of the rivets moving or falling out during alignment.

The vise shown is the Proxxon Precision Vice FMZ, with ball and socket, also available through Crafted Findings.



**Step 2** Determine the location that you would like to make the hole for your rivet. It may be helpful to make a mark with a fine point permanent marker in the location to be pierced. Turn the T-handle of the piercing punch (the tool with the extended pin) until there is enough room for the thickness of the part you wish to pierce, as shown in photo 2A. Align the point of the piercing punch with the location that you wish to pierce. Using the T-handle, slowly rotate the handle clockwise until the piece you are piercing is pinched between the tip of the punch and the base. Then continue turning the T-handle until the shoulder, indicated by red arrow in photo 2B, comes in contact with the top of the tool holder (this will ensure that the scrap slug is ejected from the base).



2A

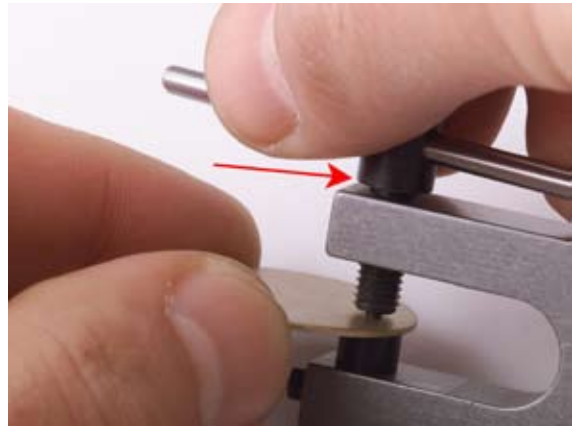

2B

**Step 3** Once the piercing punch is turned all the way to the shoulder, begin turning the T-handle counterclockwise until the piece is released from the piercing pin. (continue turning the T-handle even if the piece comes in contact with the top of the tool holder).



**Step 4** Select the proper length rivet for your application by using the chart shown in Image 4A while referencing image 4B.

Suggested Rivet Length	No. of Stacked 22 Gauge Thick pieces to be Riveted	Ideal Total Thickness (in.)	Ideal Total Thickness (mm)
1/16" (1.59mm)	1	.025-.036	.635-914
3/32" (2.38mm)	2	.050-.060	1.27-1.52
1/8" (3.18mm)	3	.075-.082	1.91-2.08
5/32" (3.97mm)	4	.100-.108	2.54-2.74

4A

A good rule of thumb is to allow half of the diameter of the rivet to protrude beyond the finished piece. For example, 1/16" Diameter rivet, allow 1/32" to protrude.

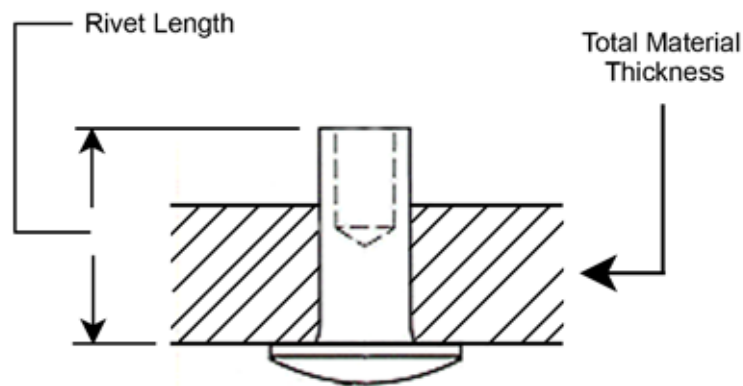

4B

**Step 5** Choose the components to be riveted.

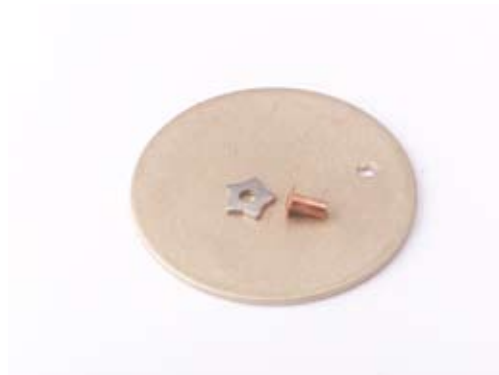

**Step 5** Pass the rivet through the holes and be sure that all pieces lay flat as shown in Photo 5B.  
continued Photo 5B.

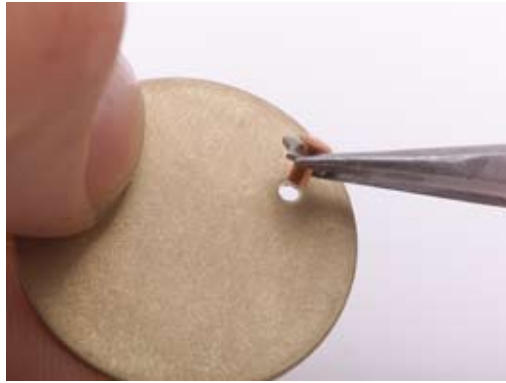

5A



5B

**Step 6** If you have not mounted the riveting tool in a vise, follow the alignment instructions in 6A. If you have mounted the tool in a vise, as shown in Step 1, follow the alignment instructions in 6B.

**6A** Hold the flaring side of the tool with the T-handle on the bottom (this orientation prevents the rivet from dropping out during the flaring operation), as shown in the photo on the right. Turn the T-handle of the flaring punch to adjust the opening between the nose of the punch and flaring base to be slightly larger than the overall height of the rivet. Then, lock the head of the rivet into the recess on the flaring base (shown on top in photo on right). Slowly turn the T-handle clockwise so the nose of the flaring punch lines up with the opening in the rivet. Once aligned, continue turning until the rivet is captured between the flaring punch and base.



**6B** Place an index card or heavy paper over the aligned rivet assembly, as shown in Photo 6C below. While holding the card tightly against the rivet assembly, flip it over and orient the head of the rivet downward, as shown in Photo 6D. Turn the T-handle of the flaring punch to adjust the opening between the nose of the punch and flaring base to be slightly larger than the overall height of the rivet. Slowly turn the T-handle clockwise so the nose of the flaring punch lines up with the opening in the rivet, as shown in Photo 6E. Once aligned, continue turning until the rivet is captured between the flaring punch and the base.



6C

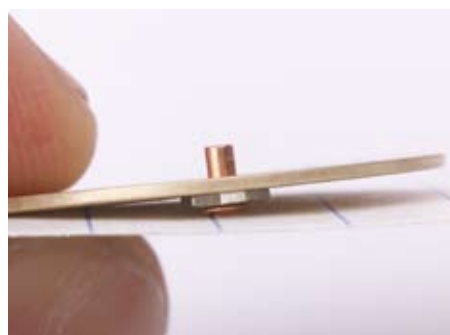

6D



6E

**Step 7** Once the rivet is aligned and captured between the flaring punch and base. Continue turning the flaring punch clockwise until flaring punch nose shoulder (shown in image 7A below) just makes contact with the surface of your work piece, as shown in photo 7B.

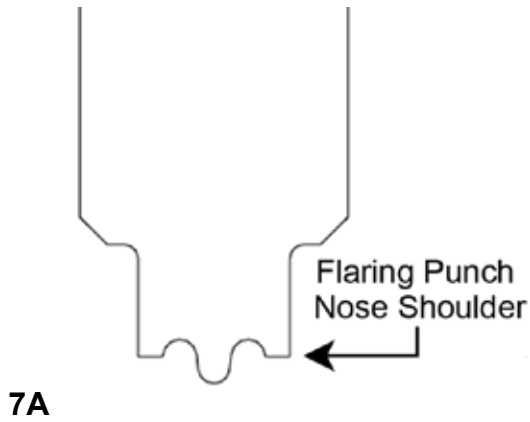

**Step 8** Turn the flaring rivet punch counterclockwise to release the rivet from the tool, revealing a clean and secure connection.

